



1506 XL MOBILE WORKBENCH EXTRA WIDTH

Body:

- > Dimensions: H 985 x W 1250 x D 550 mm
- > 30 mm thick multiplex beech wood worktop, surface additionally protected by linseed oil varnish
- > With two similar drawer blocks
- > Heel protection for your safety
- > Sheet steel, corrosion resistant and scratch-proof powder-coated, GEDORE blue

Drawers:

- > Central locking with cylinder lock
- > Wide drawers (W 480 x D 400 mm) fully extendable, removable
- > Each drawer with safety locking, single-hand operation
- > Ball-bearing guide rails
- > Can be individually equipped with lengthwise and crosswise dividers (can be ordered individually)
- > Load capacity per drawer 40 kg, bottom heavy-duty drawers 60 kg
- > Sheet steel, corrosion resistant and scratch-proof powder-coated, GEDORE blue

GEDORE High-performance chassis:

- > Total load capacity 700 kg, 500 kg when mobile
- > 2 high-performance wheels on roller bearings (fixed castors Ø 200 mm)
- > 2 smooth running wheels on ball bearings (swivel castors Ø 125 mm), both with total brake
- > The GEDORE trapezoidal axle construction secures smooth running, manoeuvrability and track-keeping also in case of maximum loads

Accessories:

- > 4 distance modules No. 1500 ED-70 K
- > Length- (LT) and crosswise (QT) dividers from zinc-plated sheet steel

Options:

- > Can be equipped with GEDORE tool modules (1500 ES/1500 CT)
- > Rear panel R 1504 XL-L can be added
- > Further drawer combinations on request
- > Special colours and designs available on request
- > Delivery without tools and accessories



1506 XL VARIANTS



No.	1506 XL 2511	1506 XL 2810
	14 drawers: 10x type 1, H = 67 mm 2x type 2, H = 137 mm 2x type 3, H = 207 mm	18 drawers: 16x type 1, H = 67 mm 2x type 2, H = 137 mm
H	985	985
W	1250	1250
D	550	550
mm	30	30
LD	15x	15x
CD	3x	3x
	140.0	150.0
Code	2528088	2528096

1506 XL 2511

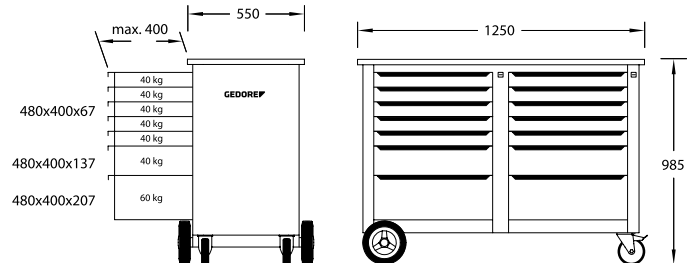

1506 XL 2810

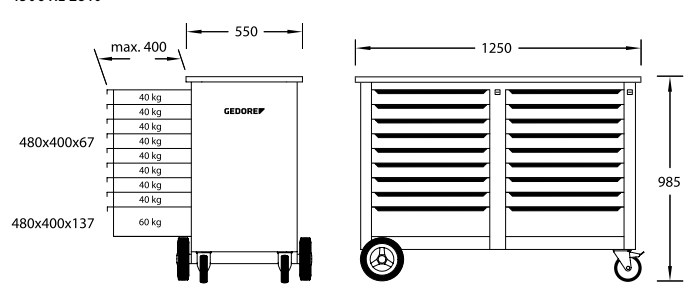

1504 MOBILE WORKBENCH

Body:

- > Dimensions: H 985 x W 1100 x D 550 mm
- > 30 mm thick multiplex beech wood worktop, surface additionally protected by linseed oil varnish
- > Large storage space with shelf and door
- > Heel protection for your safety
- > Sheet steel, corrosion resistant and scratch-proof powder-coated, GEDORE blue

Drawers:

- > Central locking with cylinder lock
- > Wide drawers (W 480 x D 400 mm) fully extendable, removable
- > Each drawer with safety locking, single-hand operation
- > Ball-bearing guide rails
- > Can be individually equipped with lengthwise and crosswise dividers (can be ordered individually)
- > Load capacity per drawer 40 kg, bottom heavy-duty drawer 60 kg (apart from no. 1504 1000)
- > Sheet steel, corrosion resistant and scratch-proof powder-coated, GEDORE blue

GEDORE High-performance chassis:

- > Total load capacity 700 kg, 500 kg when mobile
- > 2 high-performance wheels on roller bearings (fixed castors Ø 200 mm)
- > 2 smooth running wheels on ball bearings (swivel castors Ø 125 mm), both with total brake
- > The GEDORE trapezoidal axle construction secures smooth running, manoeuvrability and track-keeping also in case of maximum loads

Accessories:

- > 4 distance modules no. 1500 ED-70 K
- > Length- (LT) and crosswise (QT) dividers from zinc-plated sheet steel

Options:

- > Can be equipped with GEDORE tool modules (1500 ES/1500 CT)
- > Rear panel no. R 1504 L or RT 1504 L can be added
- > Further drawer combinations on request
- > Special colours and designs available on request
- > Delivery without tools and accessories

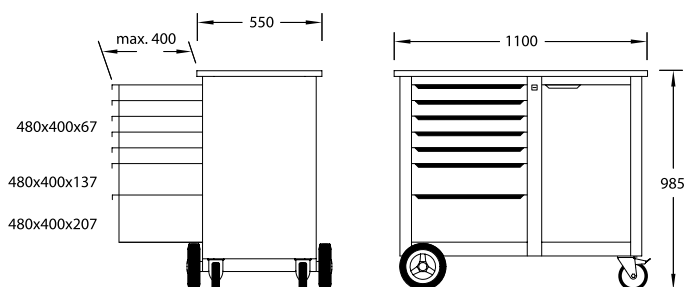



1504 VARIANTS



Code	6622830	6623050	1814958
	7 drawers: 5x type 1, H = 67 mm 1x type 2, H = 137 mm 1x type 3, H = 207 mm	7 drawers: 5x type 1, H = 67 mm 1x type 2, H = 137 mm 1x type 3, H = 207 mm	6 drawers: 3x type 1, H = 67 mm 2x type 2, H = 137 mm 1x type 3, H = 207 mm
Description	Mobile workbench with 7 drawers	Mobile workbench with 7 drawers and vice	Mobile workbench with 6 drawers
H	985	985	985
W	1100	1100	1100
D	550	550	550
LD	10x	10x	6x
CD	2x	2x	2x
	103.0	112.5	96.0
No.	1504 0511	1504 0511 S	1504 0321



Code	1814931	1814923	1814915
	8 drawers: 7x type 1, H = 67 mm 1x type 3, H = 207 mm	9 drawers: 8x type 1, H = 67 mm 1x type 2, H = 137 mm	10 drawers: 10x type 1, H = 67 mm
Description	Mobile workbench with 8 drawers	Mobile workbench with 9 drawers	Mobile workbench with 10 drawers
H	985	985	985
W	1100	1100	1100
D	550	550	550
LD	10x	15x	15x
CD	2x	3x	3x
	99.0	106.0	110.0
No.	1504 0701	1504 0810	1504 1000

1504 0511 + 1504 0511 S

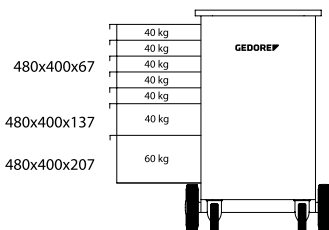

1504 0321

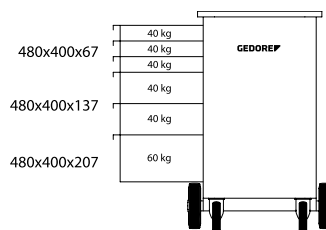

1504 0701

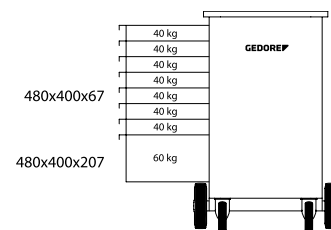

1504 0810

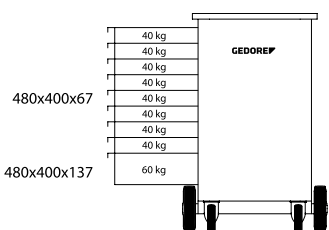

1504 1000

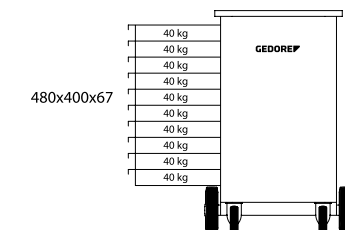

1504 XL

MOBILE WORKBENCH EXTRA WIDTH

Body:

- > Dimensions: H 985 x W 1250 x D 550 mm
- > 30 mm thick multiplex beech wood worktop, surface additionally protected by linseed oil varnish
- > Large usable storage space with shelf and door
- > Heel protection for your safety
- > Sheet steel, corrosion resistant and scratch-proof powder-coated, GEDORE blue

Drawers:

- > Central locking with cylinder lock
- > 1 XL drawer (W 1055 x D 400), 6 wide drawers (W 640 x D 400 mm) fully extendable, removable
- > Each drawer with safety locking, single-hand operation
- > Ball-bearing guide rails
- > Can be individually equipped with lengthwise and crosswise dividers (can be ordered individually)
- > Load capacity per drawer 40 kg, bottom heavy-duty drawer 60 kg
- > Sheet steel, corrosion resistant and scratch-proof powder-coated, GEDORE blue

GEDORE High-performance chassis:

- > Total load capacity 700 kg, 500 kg when mobile
- > 2 high-performance wheels on roller bearings (fixed castors Ø 200 mm)
- > 2 smooth running wheels on ball bearings (swivel castors Ø 125 mm), both with total brake
- > The GEDORE trapezoidal axle construction secures smooth running, manoeuvrability and track-keeping also in case of maximum loads

Accessories:

- > 10 length- (LT) and 2 crosswise (QT) dividers from zinc-plated sheet steel

Options:

- > Can be equipped with GEDORE tool modules (1500 ES/1500 CT or 2005 CT)
- > Rear panel R 1504 XL-L can be added
- > Further drawer combinations on request
- > Special colours and designs available on request
- > Delivery without tools and accessories



H	W	D	mm	kg	Code	No.
985	1250	550	30	120.0	1988468	1504 XL

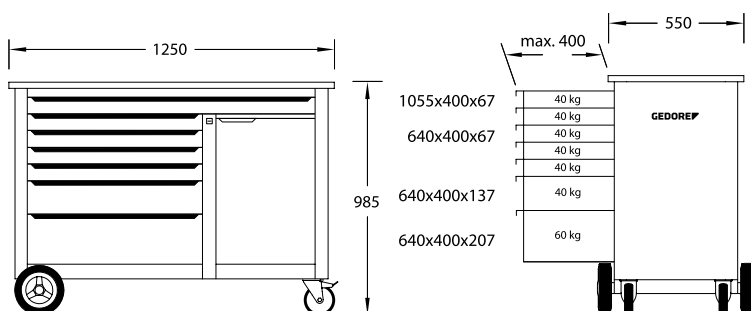



BR 1504 MOBILE WORKBENCH

with self raising rear panel

Body:

- > Dimensions: H 985 x W 1100 x D 550 mm
- > 30 mm thick multiplex beech wood worktop, surface additionally protected by linseed oil varnish
- > Large usable storage space with shelf and door
- > With rear panel, square perforation 10 x 38 mm to fix hooks and tools, with lowering mechanism, can be raised by 2 gas springs
- > Heel protection for your safety
- > Sheet steel, corrosion resistant and scratch-proof powder-coated, GEDORE blue

Drawers:

- > Central locking with cylinder lock
- > Wide drawers (W 480 x D 400 mm) fully extendable, removable
- > Each drawer with safety locking, single-hand operation
- > Ball-bearing guide rails
- > Can be individually equipped with lengthwise and crosswise dividers (can be ordered individually)
- > Load capacity per drawer 40 kg, bottom heavy-duty drawer 60 kg
- > Sheet steel, corrosion resistant and scratch-proof powder-coated, GEDORE blue

GEDORE High-performance chassis:

- > Total load capacity 700 kg, 500 kg when mobile
- > 2 high-performance wheels on roller bearings (fixed castors Ø 200 mm)
- > 2 smooth running wheels on ball bearings (swivel castors Ø 125 mm), both with total brake
- > The GEDORE trapezoidal axle construction secures smooth running, manoeuvrability and track-keeping also in case of maximum loads

Accessories:

- > 2 distance modules No. 1500 ED-70 K
- > 10 length- (LT) and 2 crosswise (QT) dividers from zinc-plated sheet steel

Options:

- > Can be equipped with GEDORE tool modules (1500 ES/1500 CT)
- > Further drawer combinations on request
- > Special colours and designs available on request
- > Delivery without tools and accessories

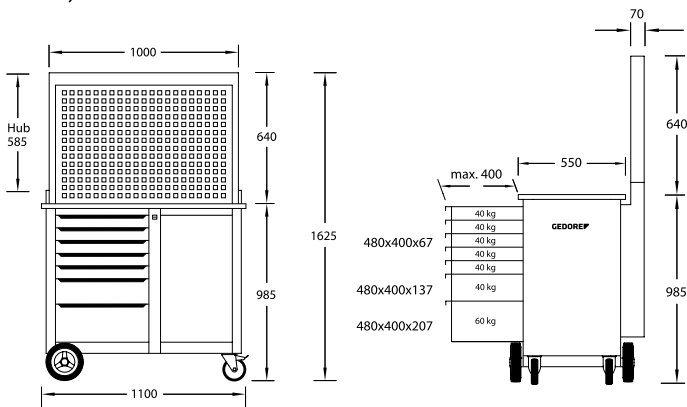

Description	H	W	D	mm	LD	CD	mm	Code	No.
Workbench with rear panel	985	1100	550	30	10x	2x	128.0	6624450	BR 1504 0511 L
Workbench with rear panel + hook assortment	985	1100	550	30	10x	2x	130.0	6623990	BR 1504 0511 LH
Workbench with rear panel + vice	985	1100	550	30	10x	2x	142.5	6624370	BR 1504 0511 S

411 >554

1500 ES / 1500 CT >98/105

BR 1500 LH WORKBENCH WITH TOOL CABINET

Body workbench:

- > Dimensions: H 900 x W 2000 x D 875 mm
- > 40 mm thick multiplex beech wood worktop, surface additionally protected by linseed oil varnish
- > Large storage space with shutter
- > Heel protection for your safety
- > Sheet steel, corrosion resistant and scratch-proof powder-coated, GEDORE blue

Body cabinet:

- > Dimensions: H 890 x W 1810 x D 170 mm
- > Shutter with cylinder lock
- > Rear panel with square perforation 10 x 38 mm to fix hooks and tools
- > Sheet steel, corrosion resistant and scratch-proof powder-coated, GEDORE blue
- > Shutter from sheet steel, corrosion resistant and scratch-proof powder-coated, GEDORE blue

Drawers workbench:

- > Separate central locking of drawers and shutter with cylinder locks
- > 5 wide drawers (W 480 x D 550 mm), extendable up to 505 mm, removeable
- > Ball-bearing guide rails
- > Can be individually equipped with lengthwise and crosswise dividers (can be ordered individually)
- > Load capacity per drawer 40 kg
- > Sheet steel, corrosion resistant and scratch-proof powder-coated, GEDORE blue
- > Total load capacity (workbench) 2000 kg

Accessories:

- > 85-piece hook assortment 1500 HS 23
- > 9 length- (LT) and 9 crosswise (QT) dividers from zinc-plated sheet steel

Options:

- > Can be equipped with GEDORE tool modules (1500 ES/1500 CT)
- > Special colours and designs available on request
- > Delivery without tools and accessories

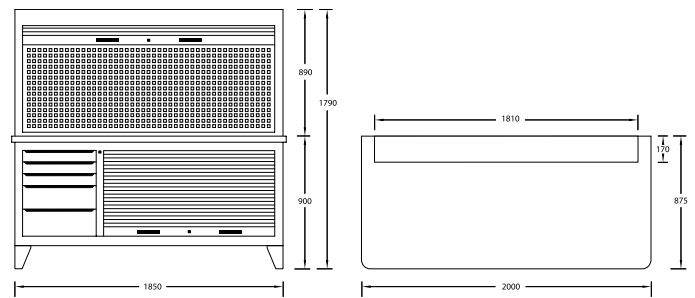
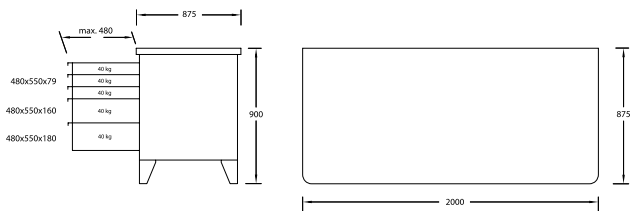

BR 1500 VARIANTS



No.	BR 1500 LH	B 1500 L	R 1500 L
Description	Workbench with tool cabinet	Workbench without tool cabinet	Tool cabinet with blind, empty
H	1790	900	890
W	2000	2000	1810
D	875	875	170
mm	40	40	
LD	9x	9x	
CD	9x	9x	
kg	203.7	166.0	78.0
Code	6618210	6618050	6617910



1502

MOBILE WORKBENCH

Body:

- > Dimensions: H 875 x W 950 x D 550 mm
- > 25 mm thick multiplex beech wood worktop, surface additionally protected by linseed oil varnish
- > Large, easily-accessible spaces for bulky parts
- > Heel protection for your safety
- > Sheet steel, corrosion resistant and scratch-proof powder-coated, GEDORE blue

Drawers:

- > Central locking with cylinder lock
- > 6 wide drawers (W 480 x D 400 mm) fully extendable, removable
- > Each drawer with safety locking, single-hand operation
- > Ball-bearing guide rails
- > Can be individually equipped with lengthwise and crosswise dividers (can be ordered individually)
- > Load capacity per drawer 40 kg, bottom heavy-duty drawer 60 kg
- > Sheet steel, corrosion resistant and scratch-proof powder-coated, GEDORE blue

GEDORE High-performance chassis:

- > Total load capacity 700 kg, 500 kg when mobile
- > 2 high-performance wheels on roller bearings (fixed castors Ø 200 mm)
- > 2 smooth running wheels on ball bearings (swivel castors Ø 125 mm), both with total brake
- > The GEDORE trapezoidal axle construction secures smooth running, manoeuvrability and track-keeping also in case of maximum loads

Accessories:

- > 2 distance modules No. 1500 ED-70 K
- > 10 length- (LT) and 2 crosswise (QT) dividers from zinc-plated sheet steel

Options:

- > Can be equipped with GEDORE tool modules (1500 ES/1500 CT)
- > Special colours and designs available on request
- > Delivery without tools and accessories

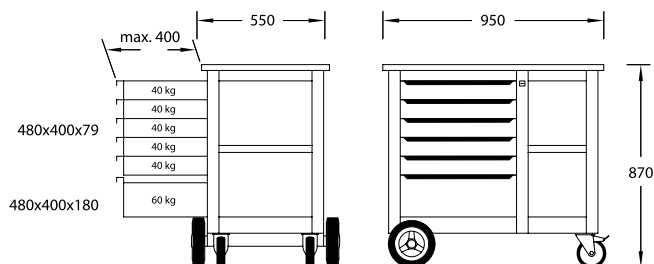

Description	H	W	D	mm	LD	CD		Code	No.
Mobile workbench	870	950	550	25	10x	2x	78.0	6620540	1502
Mobile workbench with vice	870	950	550	25	10x	2x	85.0	6620620	1502 S

Folding workbench

B 1525 FOLDING WORKBENCH

Body:

- > Dimensions: H 810/140 x W 1000 x D 700 mm
- > Strong beech wood worktop with zinc-plated steel edge protector - corrosion resistant
- > Stable folding, space-saving and mobile

GEDORE Base:

- > Total load capacity 500 kg
- > Steel tube, corrosion resistant and scratch-proof powder-coated, GEDORE blue
- > Delivery without tools and accessories

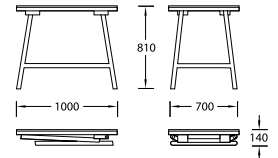

H	W	D	mm	kg	Code	No.
810	1000	700	30	32.0	6622910	B 1525

Accessories for Workbenches

R 1504 L REAR PANEL

- > Can be attached to workbench 1504 or 1505
- > Automatically raised by two gas springs, lockable with cylinder lock
- > Neat arrangement of tools
- > Square perforation 10 x 38 mm
- > Dimensions: H 640 x W 1000 x D 70 mm
- > GEDORE blue
- > Execution LH with hook assortment No. 1504 HS

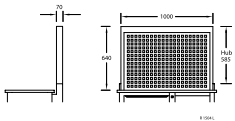

Description	H	W	D	kg	Code	No.
Rear panel empty	640	1000	70	28.0	6623800	R 1504 L
Rear panel empty with hook assortment	640	1000	70	30.0	6624020	R 1504 LH

R 1504 XL-L REAR PANEL

- > Can be attached to workbench 1504 XL, 1506 XL
- > Automatically raised by two gas springs, lockable with cylinder lock
- > Neat arrangement of tools
- > Square perforation 10 x 38 mm
- > Dimensions: H 640 x W 1190 x D 70 mm
- > GEDORE blue
- > Execution LH with hook assortment No. 1504 HS

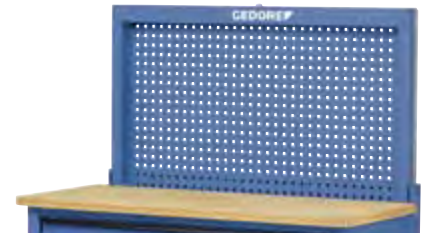

Description	H	W	D	kg	Code	No.
Rear panel empty	640	1190	70	29.0	2251787	R 1504 XL-L
Rear panel empty with hook assortment	640	1190	70	31.0	2251795	R 1504 XL-LH

RT 1504 L REAR PANEL BOARD

- > Can be attached to workbenches 1504 and 1505
- > Square perforation 10 x 38 mm
- > GEDORE blue
- > Including attachment material



H	W	D	kg	Code	No.
715	1025	30	5.0	2477025	RT 1504 L



Accessories Tool Trolleys / Workbenches

1500 H 13 ANTI-SLIP MAT

Products sold by the metre

- > For all drawers in GEDORE tool trolleys and workbenches
- > Various areas of application: Workshop, household, car, spare time...
- > Enormous slip resistance on many different surfaces
- > Can be cut to size
- > Resistant to temperatures from -30 °C to +100 °C
- > Melting point approx. +250 °C
- > Flame resistant
- > Resistant to chemicals
- > Shock- and noise absorbing
- > Dimensions: W 475 x L 2000 mm

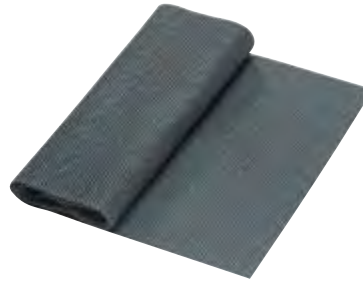

L m	W		Code	No.
2	475	0.540	5790250	1500 H 13

Drawer Partitions

E-1500 - E-2500 LENGTHWISE DIVIDER

slotted

- > In two different heights
- > In five different lengths for varying drawer depths
- > In zinc-plated sheet steel



H	L	for use with		Code	No.
42	317	1580	0.136	5325840	E-1580/14
60	320	1430	0.190	5326570	E-2500/62
60	395	2005, 1504 XL (type 1), 1506 XL (type 1), 2430	0.235	1886932	E-2005 KL/42
60	397	1502 (1-5), 1504 (1-6), 2004 (type 1)	0.208	5326490	E-1504 KL/57
60	548	B 1500 (1-3), 1505 (1-3)	0.312	5315880	E-B 1500/38

E-2005 CT LENGTHWISE DIVIDER

without slots

- > To fix the modules 2005 CT2

H		Code	No.
40	0.248	2104601	E-2005 CT H-40

E-1580 CROSSWISE DIVIDER

- > Usage: 1580
- > In three different lengths, to fit the lengthwise dividers
- > In zinc-plated sheet steel



E-1580/11-40

L	H		Code	No.
40	40	0.012	1394878	E-1580/11-40
80	40	0.024	5325760	E-1580/11-80
120	40	0.036	5326140	E-1580/11-120

E-3000 CROSSWISE DIVIDER

- > Usage: 1430, B 1500 (1-3), 1502 (1-5), 1504 (1-6), 1504 XL, 1505 (1-3), 1506 XL (type 1), 2004 (type 1), 2005 (type 1), 2430
- > In zinc-plated sheet steel



L	H		Code	No.
80	55	0.035	5326060	E-3000/37-80
120	55	0.050	5326220	E-3000/37-120

Tool Cabinets

1400 L TOOL CABINET

Body:

- > Dimensions: H 970 x W 650 x D 250 mm
- > Sheet steel, corrosion resistant and scratch-proof powder-coated, GEDORE blue
- > With storage, three drawers and fixed tool holders, e.g. for set S 1400
- > With loose modules for sockets, ratchets, extensions, etc.

Doors:

- > Central locking with cylinder lock

Drawers:

- > 2 drawers (W 478 x D 210 x H 46 mm)
- > 1 drawer (W 478 x D 210 x H 72 mm)
- > Sheet steel, corrosion resistant and scratch-proof powder-coated, GEDORE blue

Options:

- > Special colours and designs available on request
- > Delivery without tools and accessories



H	W	D		Code	No.
970	650	250	33.0	6612600	1400 L

1401 L TOOL CABINET

Body:

- > Dimensions: H 970 x W 650 x D 250 mm
- > Sheet steel, corrosion resistant and scratch-proof powder-coated, GEDORE blue
- > Doors and body with Euro perforation 10 x 38 mm to fix hooks
- > With three drawers
- > With loose modules for sockets, ratchets, extensions, etc.

Doors:

- > Central locking with cylinder lock

Drawers:

- > 2 drawers (W 478 x D 210 x H 46 mm)
- > 1 drawer (W 478 x D 210 x H 72 mm)
- > Sheet steel, corrosion resistant and scratch-proof powder-coated, GEDORE blue

Options:

- > Special colours and designs available on request
- > Delivery without tools and accessories



Compilation	H	W	D		Code	No.
Cabinet empty	970	650	250	39.0	5610610	1401 L
Cabinet 1401 L	970	650	250	34.0	6611550	1401 LH
+ hook assortment 1500 HS 11						

Tool Panels

R 1500 L TOOL CABINET

- > Suitable as workbench top

Body:

- > Dimensions: H 890 x W 1810 x D 170 mm
- > Sheet steel, corrosion resistant and scratch-proof powder-coated, GEDORE blue
- > Rear wall with Euro perforation 10 x 38 mm to fix hooks

Shutter:

- > Central locking with cylinder lock
- > Sheet steel, corrosion resistant and scratch-proof powder-coated, GEDORE blue

Options:

- > Special colours and designs available on request
- > Delivery without tools and accessories



Compilation	H	W	D		Code	No.
Cabinet empty	890	1810	170	78.0	6617910	R 1500 L
Cabinet R 1500 L	890	1810	170	81.2	6619100	R 1500 LH
+ hook assortment 1500 HS 23						

1450 L TOOL PANEL

- > Proposed tool assortment serves as the basic equipment for workshop, garage or hobby
- > Further panels can be added in either direction, with special spacers for wall fitting
- > Made from solid sheet steel 1.5 mm thick, all 4 edges are bevelled
- > Euro perforation 10 x 38 mm
- > Dimensions: L 987 x H 493 mm
- > GEDORE blue powder-coated
- > Tools not supplied

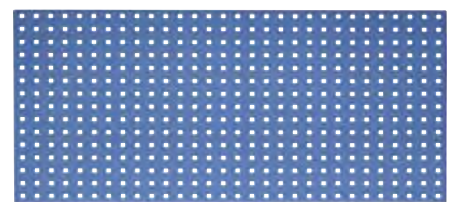

L	H		Code	No.
987	493	5.5	5617110	1450 L