



Unilifter U6 ▶▶ For heavy loads up to 6 tons

Features:

- An all-purpose toe jack for horizontal and vertical use

Technical data

U6

Item number	13292
Full load capacity	60 kN (6 t)
Working pressure	720 bar
Minimum loading height using safety toe	18 mm
Lifting height	115 mm
Loading height using top plate	265 mm
Overall dimensions (L x W x H)	306 x 146 x 265 mm
Tare weight in kg with oil fill	15 kg

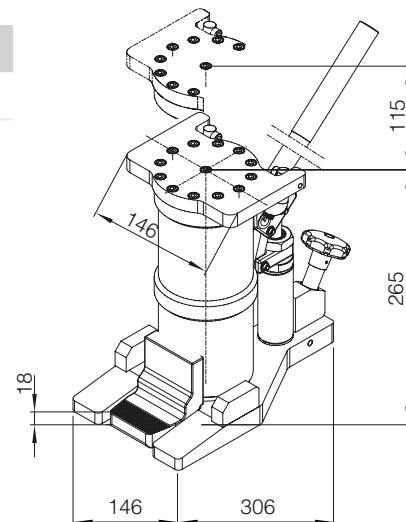
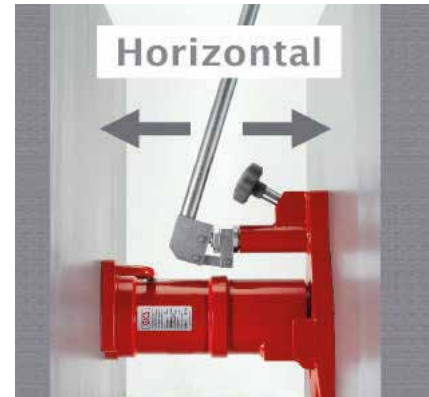



Synchronous lifting device Quadro 60 ▶▶ For heavy loads up to 60 tons

Features:

- The synchronous lifting device secures synchronous lifting or lowering of loads regardless of weight distribution. It has been designed specifically for four of our standard toe jacks, max. models V15 / V15EX, which results in a total lifting capacity of up to 60 t.
- The toe jacks can be set to the desired positions individually from the control panel, in case of differing loading heights, and then be raised synchronously.
- The operation is carried out via an electric pump with remote control.
- The toe jacks are connected via 8 m long hoses, which are stored on four hose reels, equipped with an automatic retraction system.
- The system includes a heavy-duty trolley.



Contents

Hydraulic
Toe Jacks

Pumps

Transport
Trolleys

Rotating
Trolleys

Transport Module
ROBOT

Wheels

Special
Transport Trolleys

Repair
Services

Technical data

Quadro 60

Item number	13826 *
Max. load capacity	600 kN (60 t) **
Working pressure	520 bar
Compatible with four toe jacks each	For GKS toe jacks V5 to V15 and V5-EX to V15-EX
Hydraulic unit	Electric pump PE ***
Dimensions (L x W x H)	2000 x 800 x 1480 mm
Hose connection	4 x 8 m ****
Total weight	400 kg *****



- * Toe jacks are not included with the supply
- ** Depending on the size of the toe jack
- *** Other pump sizes are possible
- **** Custom lengths available on request, depending on hose connection, coupling + quick-release fastener
- ***** Depending on accessories / toe jacks